

3D VIEW (REFERENCE)

ENTERY INDUSTRIAL CO., LTD.

FEB - 4. 2016

R&D D.C.C. ISSUED

NOTES: MATERIAL & FINISH

- HOUSING: HIGH-TEMP THERMOPLASTIC UL94V-0
COLOR: BLACK
- ACTUATOR: HIGH-TEMP THERMOPLASTIC UL94V-0
COLOR: NATURAL
- TERMINAL: COPPER ALLOY
PLATING: GOLD-FLASH ON CONTACT & SOLDERING AREA
OR MATTE-TIE 100~160u" (LEAD FREE)
- FITTING NAIL: COPPER ALLOY
PLATING: MATTE-TIN PLATED
- ORDER INFORMATION: 6782K-X XX X-00 X

PACKING: E: TUBE
R: PLASTIC CARRIER
L: PAPER CARRIER
TYPE
N: STANDARD
M: MALAR

PIN NO.
△ PLATING: Y: GOLD FLASH ON CONTACT & SOLDERING AREA OVERALL
50~100u" NICKEL UNDER PLATED.
Q: MATTE-TIE 100~160u"

0.8MM ZIF FPC SMT R/A B/C TYPE (HALOGEN FREE)

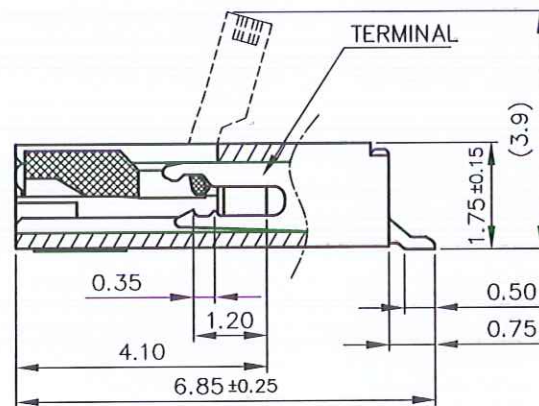
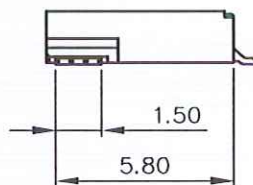
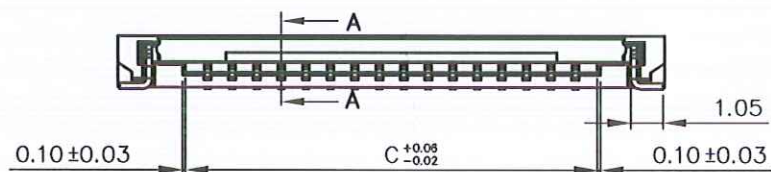
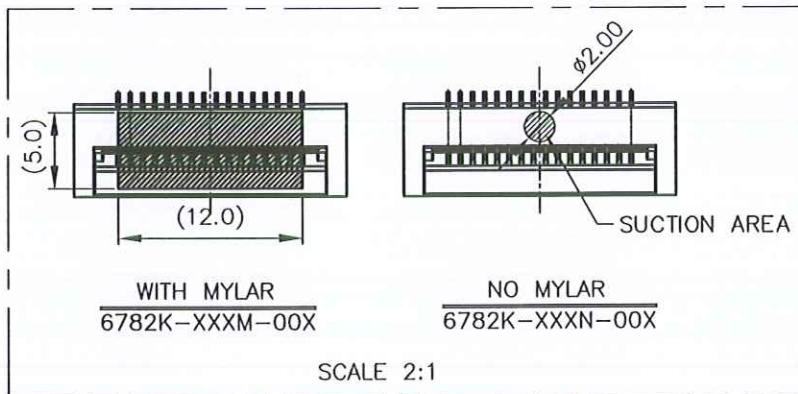
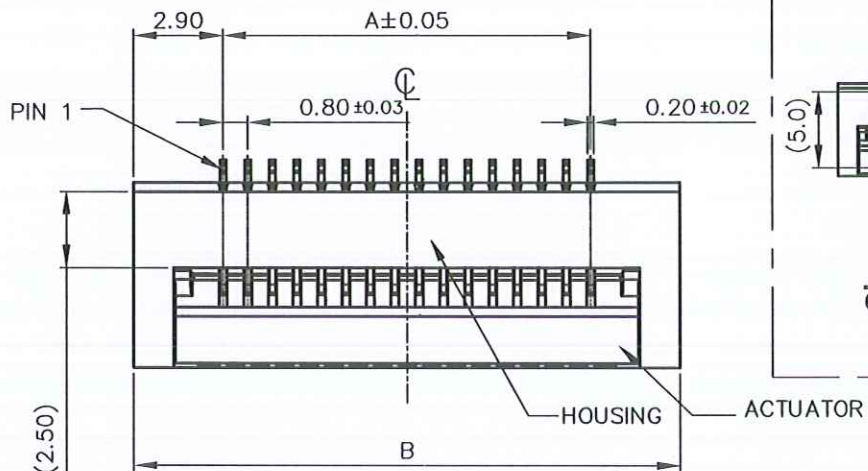

SECTION AA
SCALE 8:1

PIN NO.	DIM A.	DIM B.	DIM C.	DIM D.
12	8.80	14.60	10.23	10.43
13	9.60	15.40	11.03	11.23
14	10.40	16.20	11.83	12.03
15	11.20	17.00	12.63	12.83
16	12.00	17.80	13.43	13.63
17	12.80	18.60	14.23	14.43
18	13.60	19.40	15.03	15.23
19	14.40	20.20	15.83	16.03
20	15.20	21.00	16.63	16.83
21	16.00	21.80	17.43	17.63
22	16.80	22.60	18.23	18.43
23	17.60	23.40	19.03	19.23
24	18.40	24.20	19.83	20.03
25	19.20	25.00	20.63	20.83
26	20.00	25.80	21.43	21.63
27	20.80	26.60	22.23	22.43
28	21.60	27.40	23.03	23.23
29	22.40	28.20	23.83	24.03
30	23.20	29.00	24.63	24.83
32	24.80	30.60	26.23	26.43
34	26.40	32.20	27.83	28.03

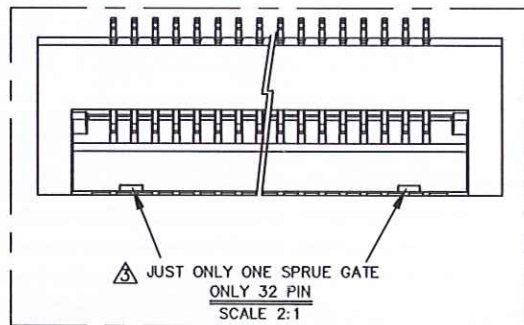

CUSTOMER		恩得利工業股份有限公司 ENTERY INDUSTRIAL CO., LTD.	
GENERAL TOLERANCE UNLESS OTHERWISE SPECIFIED X.X ±0.25 X.XX ±0.15 X.XXX ANG. ±2°		DRAWN KAZ JUL-13-2011 CHECKED <i>[Signature]</i> APPROVED <i>[Signature]</i> SHEET 1/2	PART NO. 6782K-XXXX-00X TITLE: 0.8mm PITCH FPC R/A SMT H1.8 UNIT SCALE SIZE REV MM 4:1 A4 F
SER	REVISIONS	CHK	DATE

SER	REVISIONS	CHK	DATE
△	REN160201	Jun0	02/03/16
△	RE201304010	Ceres	06/16/15
△	RE201504010	Jun0	05/08/15
△	REN130807	Jun0	08/15/13
△	REN130202	Jun0	02/04/13

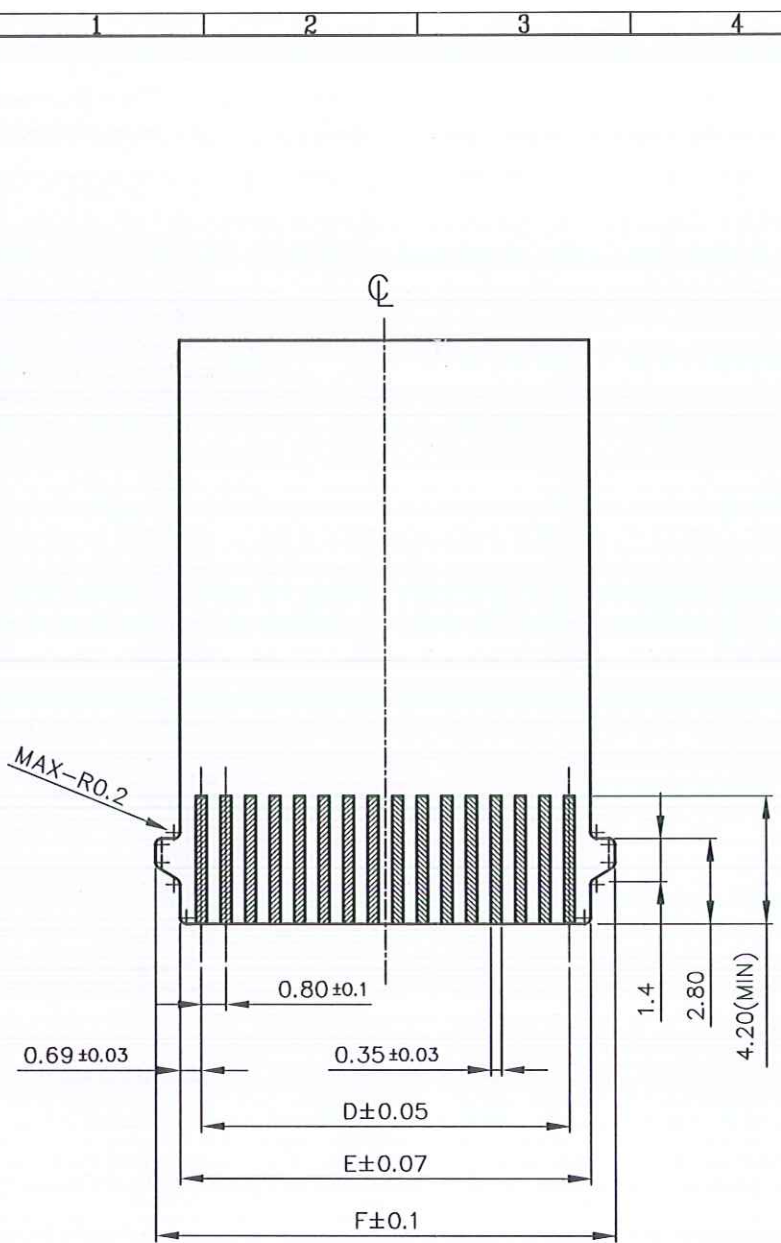

RECOMMENDED FFC DIMENSION

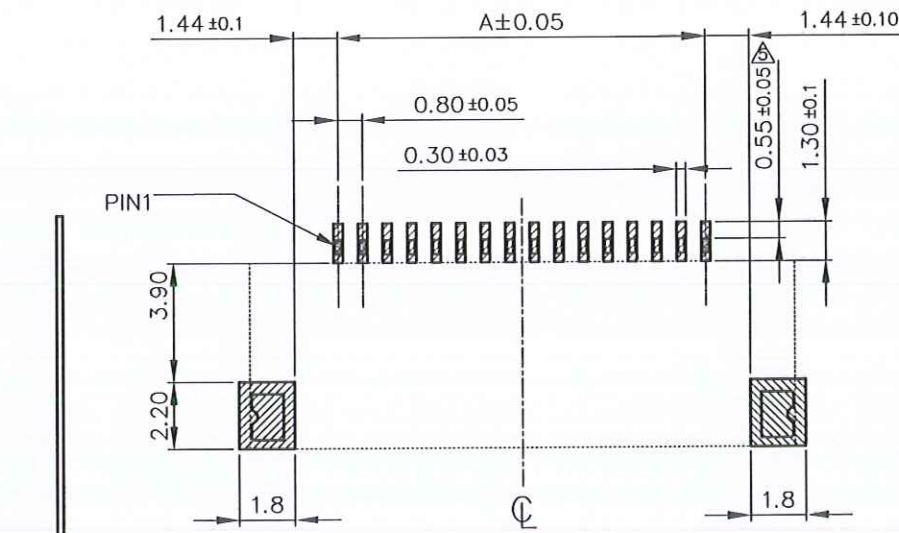

P.C.B LAYOUT REFERENCE



ENTERY INDUSTRIAL CO., LTD.
FEB - 4. 2016
R&D D.C.C. ISSUED

PIN NO.	DIM D.	DIM E.	DIM F.
12	8.80	10.18	11.78
13	9.60	10.98	12.58
14	10.40	11.78	13.38
15	11.20	12.58	14.18
16	12.00	13.38	14.98
17	12.80	14.18	15.78
18	13.60	14.98	16.58
19	14.40	15.78	17.38
20	15.20	16.58	18.18
21	16.00	17.38	18.98
22	16.80	18.18	19.78
23	17.60	18.98	20.58
24	18.40	19.78	21.38
25	19.20	20.58	22.18
26	20.00	21.38	22.98
27	20.80	22.18	23.78
28	21.60	22.98	24.58
29	22.40	23.78	25.38
30	23.20	24.58	26.18
32	24.80	26.18	27.78
34	26.40	27.78	29.38

CUSTOMER		恩得利工業股份有限公司 ENTERY INDUSTRIAL CO., LTD.	
GENERAL TOLERANCE UNLESS OTHERWISE SPECIFIED X.X ±0.25 X.XX ±0.15 X.XXX ±0.10 ANG. ±2°		DRAWN KAZ JUL-13-2011 CHECKED <i>Wei</i> APPROVED <i>L7/4</i> SHEET 2/2	PART NO. 6782K-XXXX-00X TITLE: 0.8mm PITCH FPC R/A SMT H1.8 UNIT SCALE SIZE REV MM 4:1 A4 F

SER	REVISIONS	CHK	DATE
△	REN160201	Juno	02/03/16
△	RE201304010	Ceres	06/16/16
△	RE201504010	Juno	05/06/16
△	REN130807	Juno	08/15/13
△	REN130202	Juno	02/04/13